

* MAKES LAST

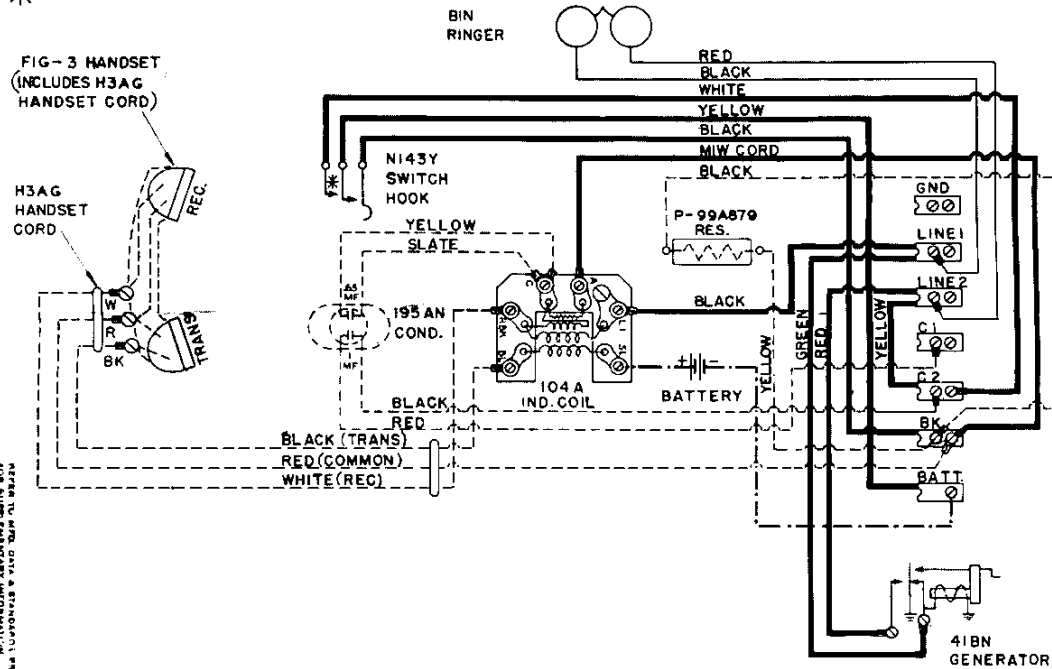

MULTIPLY NUMBER UNDER EACH SYMBOL BY 1000 UNLESS OTHERWISE SPECIFIED

NETWORKS

- A WIRING** CONNECT A MIW CORD FROM A OF INDUCTION COIL TO TERMINAL BK. IF SET IS EQUIPPED WITH A P-99A879 RESISTANCE ASSEMBLY OR 195 AN CONDENSER, CONNECT SLATE AND YELLOW LEADS FROM 195 AN CONDENSER TO TERMINAL C AND CONNECT BOTH LEADS FROM P-99A879 RESISTANCE ASSEMBLY TO TERMINAL BK.
- B WIRING** REMOVE THE MIW CORD IF PRESENT (FROM TERMINAL A TO BK). CONNECT THE BLACK LEAD FROM P-99A879 RESISTANCE ASSEMBLY TO TERMINAL A AND CONNECT THE OTHER LEAD FROM THIS RESISTANCE TO TERMINAL BK. IF THE SET IS EQUIPPED WITH A 195 AN CONDENSER, CONNECT BOTH THE YELLOW AND SLATE LEADS FROM THIS CONDENSER TO TERMINAL C.
- C WIRING** CONNECT SLATE LEAD FROM 195 AN CONDENSER TO TERMINAL C AND CONNECT YELLOW LEAD FROM THIS CONDENSER TO TERMINAL BK. REMOVE THE MIW CORD IF PRESENT (FROM TERMINAL A TO BK). IF SET IS EQUIPPED WITH A P-99A879 RESISTANCE ASSEMBLY, CONNECT BOTH LEADS FROM THIS RESISTANCE TO TERMINAL BK. CONNECT THE BLACK AND RED CONDENSER LEADS TO TERMINAL C1.

FOR SHORT CABLE LOOPS, SHORT IRON OPEN WIRE LOOPS, ALL LENGTHS OF COPPER OPEN WIRE AND LOOPS CONSISTING OF COMBINATIONS OF SHORT LENGTHS OF CABLE AND OPEN WIRE.

FOR LONG IRON OPEN WIRE LOOPS.

FOR LONG NON-LOADED CABLE LOOPS.

1. THIS SET IS SHIPPED WIRED FOR "A" NETWORK WIRING.
2. THIS SET IS SHIPPED WITH THE 195 AN CONDENSER CONNECTED IN SERIES WITH THE RECEIVER ONLY IF EQUIPPED WITH A 195 AN CONDENSER.
3. WHEN USED FOR DIVIDED RINGING, THAT IS RINGING FROM EITHER SIDE OF A METALLIC LINE, TO GROUND, CONNECT THE RED RINGER LEAD IN ONE GROUP OF SETS TO TERMINAL "LINE 1" AND IN THE OTHER GROUP TO TERMINAL "LINE 2". IN ALL SETS CONNECT THE BLACK RINGER LEAD AND THE GROUND WIRE TO TERMINAL "GND", THE TIP SIDE OF THE CENTRAL OFFICE LINE TO TERMINAL "LINE 1" AND THE RING SIDE TO TERMINAL "LINE 2".
4. TO CONNECT THE CONDENSER IN SERIES WITH THE RECEIVER, IF NOT ALREADY SO EQUIPPED, CONNECT THE WHITE LEAD FROM THE SWITCHHOOK TO TERMINAL "C1", CONNECT THE RED CONDENSER LEAD TO TERMINAL "C1" AND THE BLACK CONDENSER LEAD TO TERMINAL "C2", CONNECT THE BLACK RINGER LEAD TO TERMINAL "LINE 1" AND THE RED RINGER LEAD TO TERMINAL "C2".
5. TO CONNECT THE CONDENSER IN SERIES WITH THE RINGER, CONNECT THE BLACK RINGER LEAD TO TERMINAL "LINE 1", CONNECT THE RED RINGER LEAD TO TERMINAL "C1", CONNECT THE RED CONDENSER LEAD TO TERMINAL "C1" AND THE BLACK CONDENSER LEAD TO TERMINAL "C2". (USE WHEN CONNECTING TO COMMON BATTERY LINES AND WHEN DESIRED TO FACILITATE LINE TESTING).
6. TO CONNECT THE CONDENSER IN SERIES WITH BOTH THE RECEIVER AND THE RINGER, CONNECT THE WHITE LEAD FROM THE SWITCH HOOK TO C1, CONNECT THE BLACK CONDENSER LEAD TO C2 AND THE RED CONDENSER LEAD TO C1. CONNECT THE BLACK RINGER LEAD TO "LINE 1" AND THE RED RINGER LEAD TO C1.
7. RINGER ADJUSTMENT. DO NOT ATTEMPT TO MAKE ANY ADJUSTMENT TO THE RINGER OTHER THAN STATED HERE: THE GONGS SHOULD BE SO SET THAT THE CLAPPER BALL STRIKES BUT DOES NOT REST AGAINST THEM WHEN THROWN TO EITHER SIDE. TO CHANGE THE POSITION OF THE GONGS, LOOSEN THE MOUNTING SCREWS, TURN THE GONGS UNTIL THE CORRECT POSITION IS OBTAINED AND THEN TIGHTEN THE MOUNTING SCREWS.
8. REPAIR PARTS SHOULD BE ORDERED BY SAMPLE IF POSSIBLE, OTHERWISE BY ACCURATE DESCRIPTION. ALWAYS MENTION, IF POSSIBLE, THE CODE NUMBER OF THIS SET. (IT IS STAMPED ON THE INSIDE OF THE DOOR).

From a schematic donated by Art Harris

The Telephone on P.E.I. - <http://www.islandregister.com/phones/phones.html>